

# Reflex H1120F 24V

**1 Components required:** These items are required for installation, cutting shears sold separately.

L to R: End Cap, Terminal Insert, Silicone Glue, Cutting Shears.

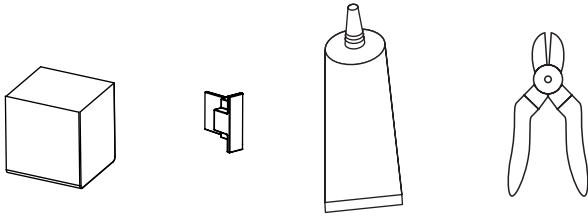

**2 Note:** Wire tails are pre-soldered and are located every 500mm on the underside of the Neonflex.

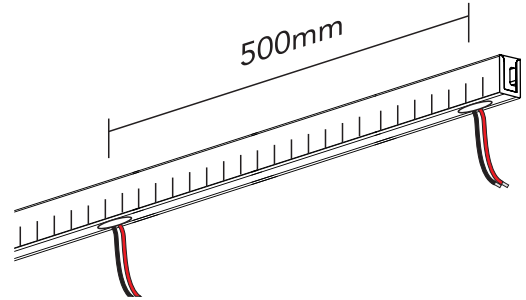

**3** Measure the Neonflex to the required length, then trim at the closest cutting mark using your shears.

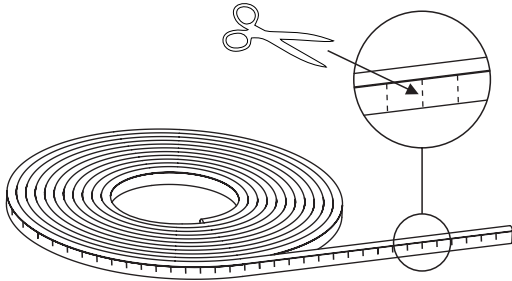

**4 DO NOT** cut over the silicone wire join on the underside of the Neonflex.

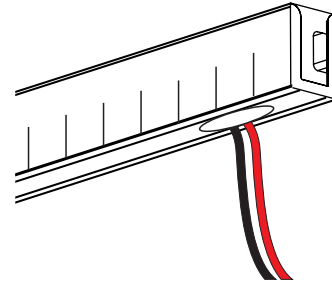

**5** Coat the terminal with silicone and insert into the end of the silicone tube.

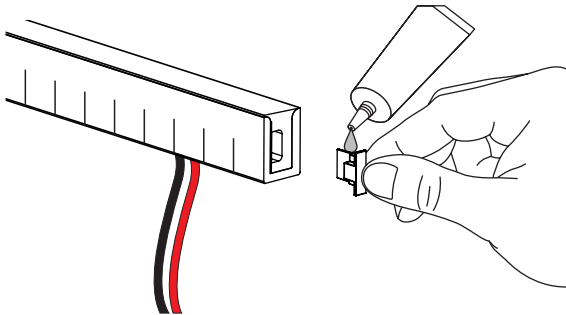

**6** Coat the end of the silicone tube with silicone and side on the end cap. Allow adequate time for the silicone to dry before connecting to an LED transformer and powering on.

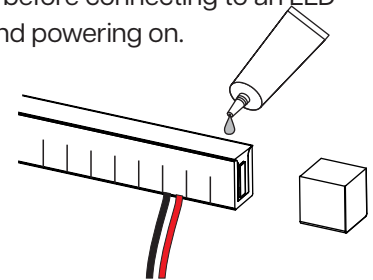

**7** Mounting options available:

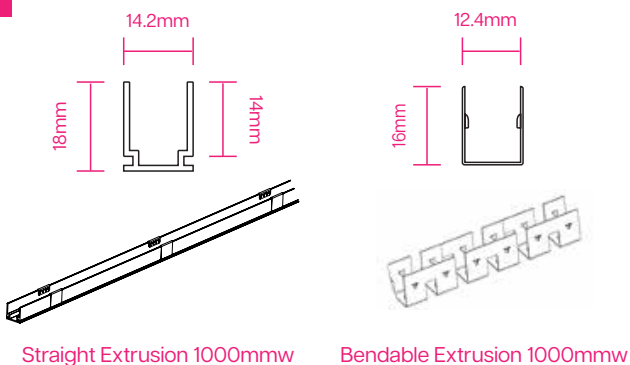

**8** This product has a horizontal bend. Avoid twisting during installation.

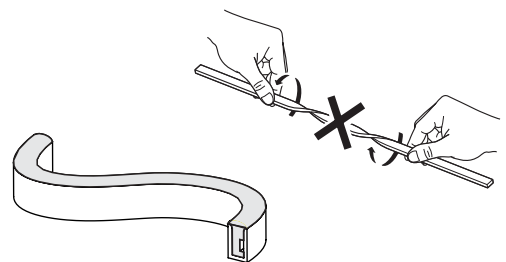

## Sales & Support